

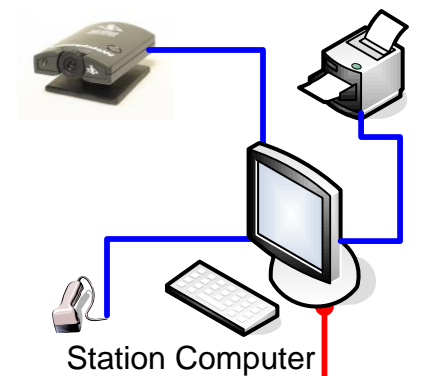

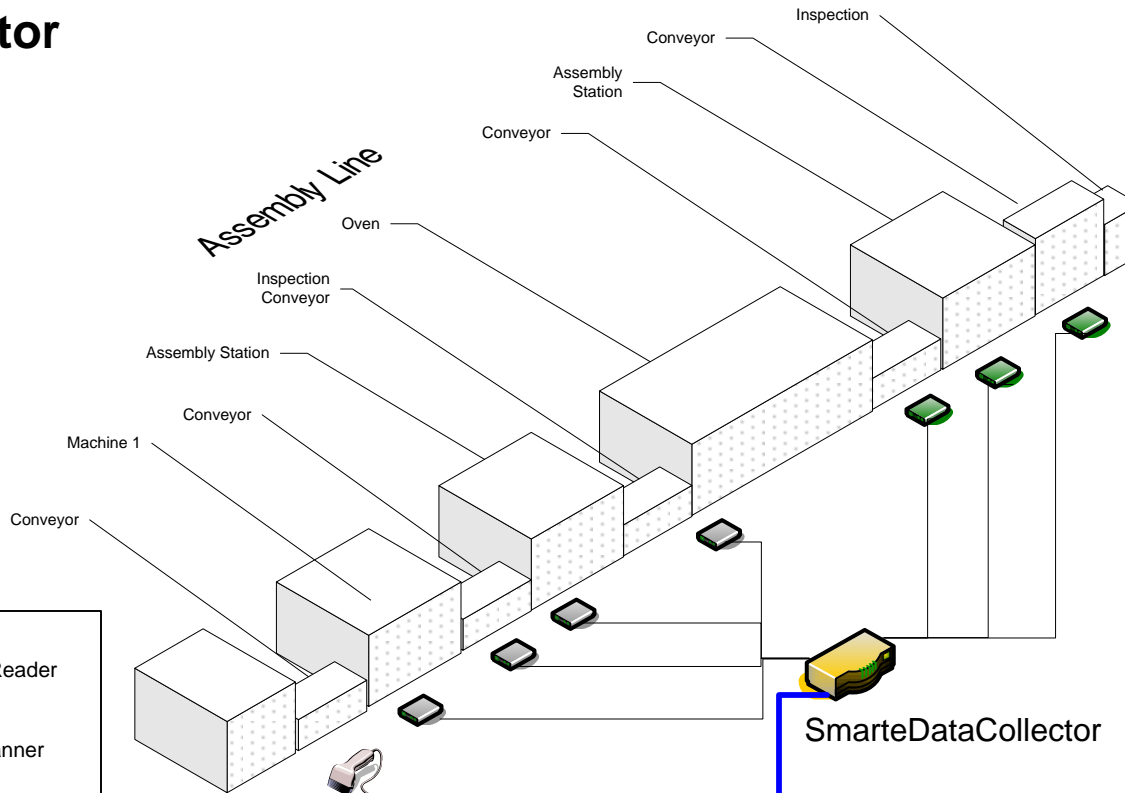





Prodesol SmarteMonitor



-  USB Fingerprint Reader
-  USB Barcode Scanner
-  USB RFID Scanner
-  USB Camera
-  USB SmarteDataCollector
-  AnywhereUSB/5
-  Digital Sensor (switch)
-  Analog Sensor

- Prodesol Sensors**
- Analog sensors Input:*
- Temperature
 - Relative Humidity
 - Gas (CO2)
 - Gas Pressure
 - Voltage
 - Amperage
 - Distance
 - Rotation
 - PH
 - Motion
 - Vibration
 - Light
- Digital Sensors Input:*
- Switches
 - Counters

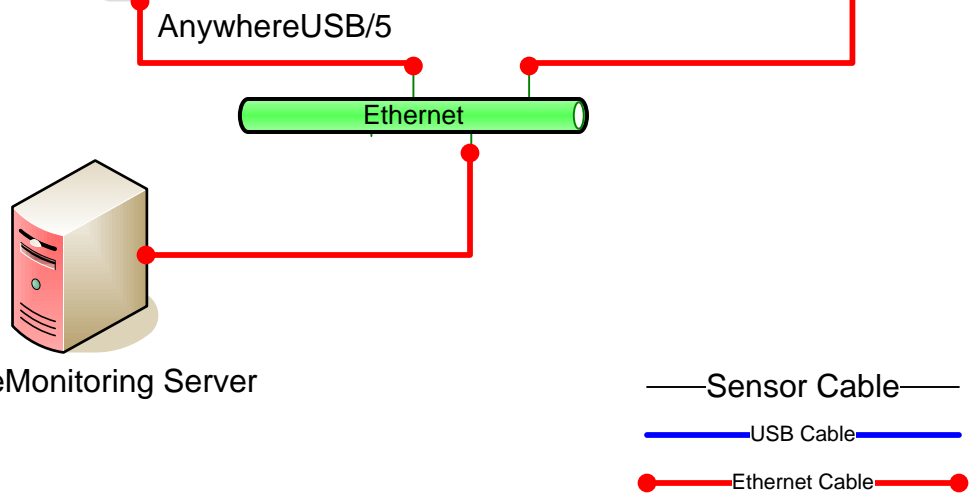
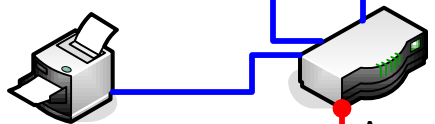

SmarteMonitoring Server

— Sensor Cable —
 — USB Cable —
 ● Ethernet Cable ●

Prodesol SmarteMonitoring Configuration

Monitoring type:

- Permanent
- Temporary

Output type:

- Local
- Server
- Dashboard

Goal:

- Optimization
- Monitoring
- Surveillance

Location:

- Workcenter
- Assembly Line

Analysis

Data

- Throughput
- Quality
- Efficiency
- Environment
- Safety
- Warnings
- Measure
- Traceability
- More...

Surveillance:

- Webcam
- Video surveillance
- Motion detection

Report:

- Graphs
- Value
- Multiple calculations

Prodesol Sensors

Analog sensors Input:

- Temperature
- Relative Humidity
- Gas (CO2)
- Gas Pressure
- Voltage
- Amperage
- Distance
- Rotation
- PH
- Motion
- Vibration
- Light
- More...

Digital Sensors Input:

- Switches
- Counters

Traceability:

- Barcode
- RFID

Surveillance:

- Webcam
- Video surveillance
- Data collection
- Motion detection